

HI-PE/CF

Very High Discrimination Metal Detector

The transit of metal personal effects in common daily use through Metal Detector checkpoints generates signals which often exceed those of some types of fire-arms available on the market. Discrimination of these by the Metal Detector therefore becomes a necessary condition for establishing access systems with high flow rates.

As a solution to this problem, CEIA presents its new **HI-PE/CF** Metal Detector which, with its detection functions based on an innovative signal analysis system, raises the threshold of discrimination between medium-sized fire-arms and personal effects to a level up to 400% above that of the 02PN8 HI-PE model.

The advantages of using this new Metal Detector are the following: a notable reduction in the need for branch staff to act to check inward- and outward-bound traffic; increase in convenience of access to the bank for customers; and, not least, the opportunity to increase the level of security.

Statistical data obtained in real operating situations with the **HI-PE/CF** Metal Detector have demonstrated the almost total elimination of false alarms compared with earlier systems, at the same level of detection capability relating to fire-arms of conventional construction and in light metal, such as the Beretta 6.35mm.

The **HI-PE/CF** Metal Detector keeps the same dimensions and programming characteristics as the 02PN8 HI-PE Metal Detector, so that it can be fitted into systems which were designed for the earlier model. As far as its application is concerned, the parameters already in use for walk-through Metal Detectors remain valid, in particular the importance of the electromagnetic compatibility of the metal structure.

In order to guarantee the levels of performance described above, use of this new Metal Detector is restricted to cabins previously certified for electromagnetic compatibility with the **HI-PE/CF** Metal Detector.



Technical Data

Main Features

- Digitally adjustable sensitivity with a wide range of values.
- International Standards: Direct selection of the International Security Standards.
- Very high discrimination.
- Very high immunity to electromagnetic and mechanical interference.
- All functions programmable and controlled by a microprocessor.
- Programming: via built-in keypad and RDU or RS232/RS485 serial connection to PC or computer network.
- Programming access protected by both a mechanical lock and by two software level passwords.
- Automatic synchronization between two or more metal detectors, at a distance of up to 5 cm, from each other, without using cables.
- Professional high integration and high reliability electronics.
- Electronic control unit separated from the archway.
- No need for initial or periodic calibration.
- Easy maintenance. The electronic control unit can be replaced in less than one minute.
- Color: light gray RAL 7040

Alarms

Acoustic signal:

- Buzzer - 90 dBA (1 m)

Relay outputs:

- NO, NC, C exchange contact - 1 A - 24 Vdc

Reset:

- PP input, automatic or manual, N.C. contact

Inhibition:

- INI input, N.O. contact

Autodiagnosis:

- Embedded, with intermittent acoustic signal

Certifications and conformity

- Harmless to wearers of pacemakers or other vital support systems, pregnant women and magnetic storage media (floppy disks, audio cassettes, video cassettes and similar).
- Conforms to the NILECJ-0601-00 standards for all security levels.
- Satisfies EC regulations and international standards relating to electrical safety and electromagnetic compatibility (EMC).

Installation Data

Power Supply:

- 20 ÷ 30 Vdc, 1 A MAX

Inputs:

- RS-232C interface for the connection with a terminal, a computer or an external modem
- RS-232C interface for the network connection with other CEIA metal detectors

Temperature and relative humidity:

- from -15°C to +70 °C; from 0 to 95% (without condensation)

Dimensions and weight of the control unit:

- 380 x 157 x 82 mm / 1,2 kg.

Accessories / Options

- Metallic test samples.

Dimensions

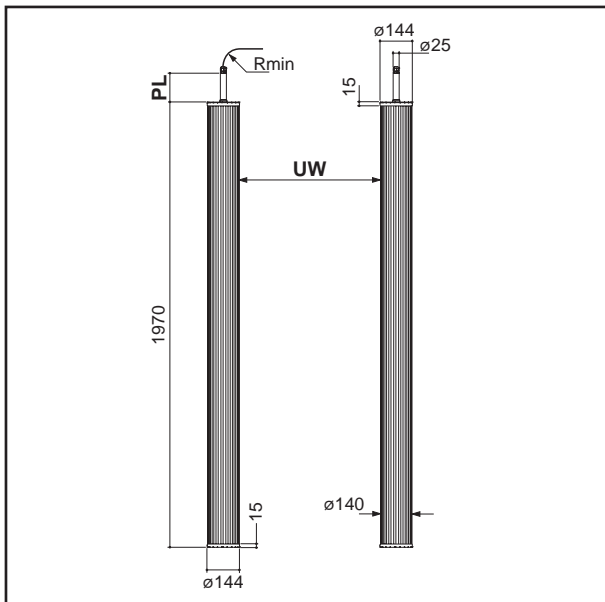

Model	HI-PE/CF
UW	640 ÷ 740
PL	40 130 250 280

Example of the model with options 2, 3 and 5 (see below)

Options

Type of cable

1 0,8m cable with connector, with 8m extension.

2 Simple 3m cable.

Anchoring

3 **Anchoring without flange**
Fixing via insertion of central conical support fixed to floor.

4 **Anchoring with flange**
Fixing via a flange with holes as shown in the picture.

Top fixing and cable exits

5 Fixing via locking of the metal tube. The cable leads out of the middle of the tube.

6 Fixing via direct locking of the column body. Axial cable exit.

7 Fixing via central screw M10x12. Off-centre cable exit.